

OPITEC

OPITEC Handel GmbH, D-97232 Giebelstadt
 OPITEC Educational Materials Ltd., GB-Southampton
 OPITEC Prod.- u. Vertriebsges. m.b.H., A-1230 Wien
 OPITEC-France S.A.R.L., 94307 Vincennes-Cdx

Tel. 0 93 34 / 94 11 11
 Tel. 0 23 / 80 44 65 15
 Tel. 01 / 8 69 30 14
 Tel. 01.49.57.50.56

OPITEC-Italia Srl, I-39043 Chiusa (BZ)
 OPITEC AG/SA, CH - 1700 Freiburg
 OPITEC-Nederland BV, NL-1871 BJ Schoorl
 OPITEC-Belgie BVBA, B-2018 Antwerpen

Tel. 0472 / 84 61 80
 Tel. 026 / 347 48 49
 Tel. 072 / 5 09 47 71
 Tel. 03 / 2 34 36 13

technobots.co.uk Part No. 1400-052

Motor and gearbox

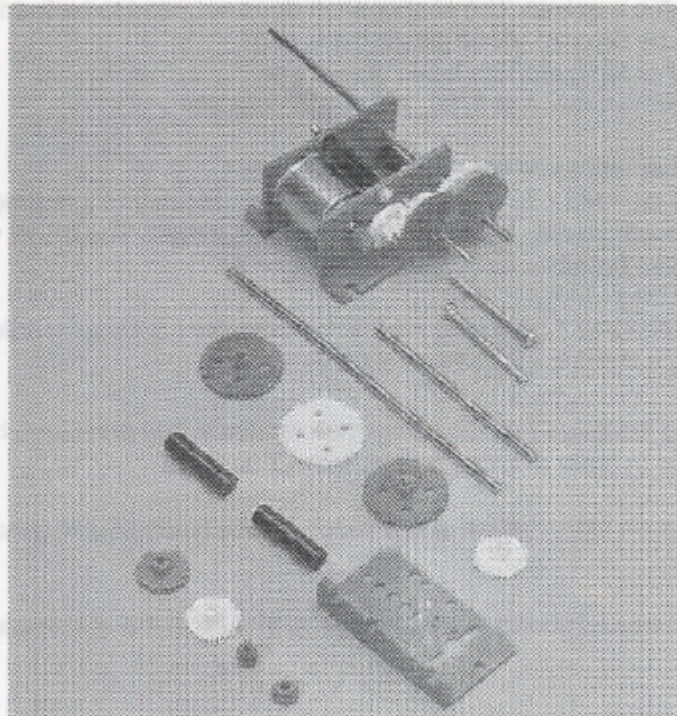

Parts List

- 1 Motor
- 1 Metal axle 3mm dia x 70mm
- 1 Metal axle 3mm dia x 120mm
- 1 Set screw 3 x 12mm
- 2 Set screws 3 x 35mm
- 2 Nuts M3
- 1 Nut M4
- 1 Brass tube 5mm
- 1 Brass tube 8mm
- 2 Double gears red 50/10
- 3 Double gears white 50/10
- 4 Double gears red 30/10
- 3 Double gears white 30/10
- 1 Motor drive gear
- 2 Mounting brackets
- 1 Plastic ring
- 2 Distance spacers 25mm

Please Note

The OPITEC range of projects is not primarily intended as toys for young children. It is for teaching, designing and making to ensure that pupils experience a range of tools and processes.

Assembly

1. Insert the M3 x 35mm long machine screws in the first angle bracket, (where shafts are not needed- see diagram) add the distance tubes (25mm long) Then mount the second bracket on the end of the screws. Add M3 nuts (screw these on about 3mm). The feet on the brackets can face inwards or outwards.
2. Locate the motor in between the brackets, with the ends inserted into the central holes in the slots. Tighten up the M3 nuts on the machine screws, checking that the motor is correctly located. Add the motor drive pinion gear.
3. Tap a short shaft carefully into a red double gear 50 /10 T. Repeat the same process with a longer shaft.

Red gears = tight fit on the shaft
White gears = loose fit on the shaft

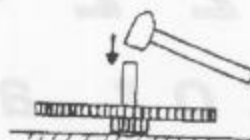

4. The third double gear runs loose on the shaft. Now you can insert the shafts in the upper, middle and lower range of holes in the brackets. The shorter shaft does not need to be fixed as it cannot fall out. The longer shafts must be secured with a plastic fixing ring. The ring can be applied or removed with a pair of pliers. With this type of arrangement ratios of 5, 25, 125 :1 are possible.
5. If you want to make other ratios you will need a 30/10 T gear. The idler gear runs free on a M3 x 12 machine screw, with a M4 nut as a distance piece. This is screwed into the 2.8mm dia. hole and will cut its own thread. The screw will need to be fully inserted so that it is as tight as possible. The ratio is now a slow 3:1. By adding a double gear 30/10 T on a long shaft 9:1 is possible (3 bearing holes available) With a 50/10 double gear, ratios of 15:1, 45:1 can be achieved.

Note: Assembling the gears may be sometimes require a little pressure, however there should be enough give in order to arrange them without damage

6. If you wish to achieve even higher ratios, add a second loose fitting double gear 30/10 to the shaft. (see diagrams)
7. Add the brass spacer tubes as shown in the diagram to ensure that any side play in the gears is kept to a minimum.

Assembly

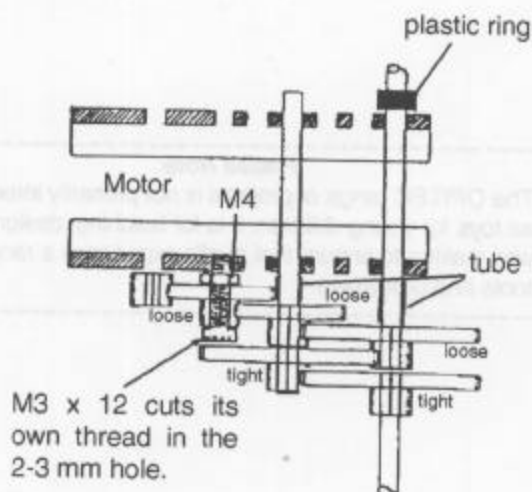
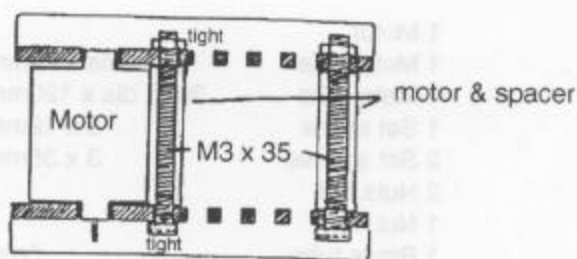

Variations

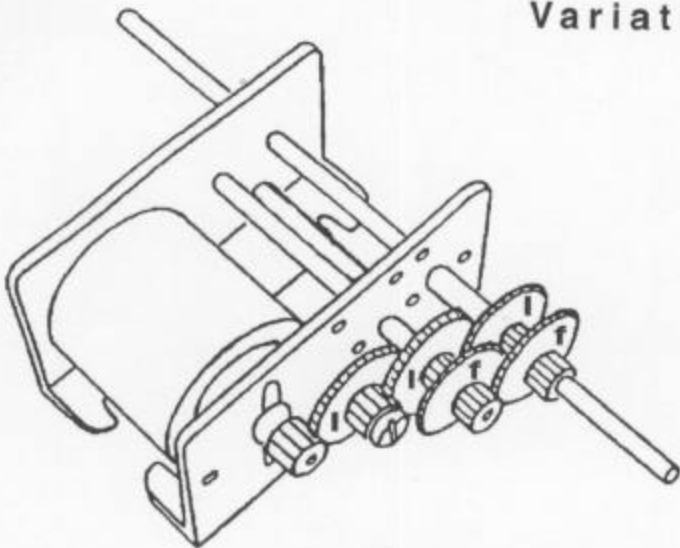

$r = 243 : 1$

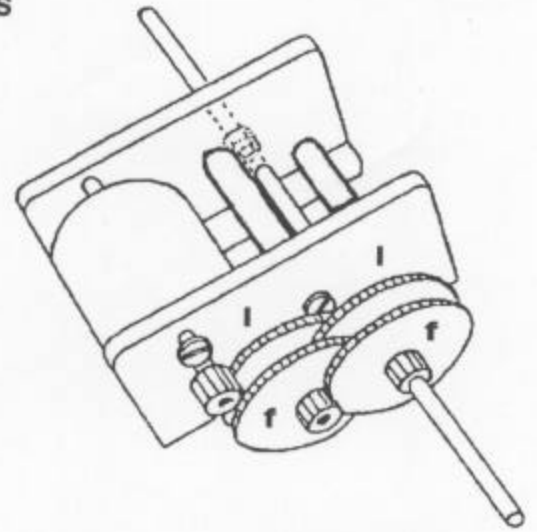

$r = 125 : 1$

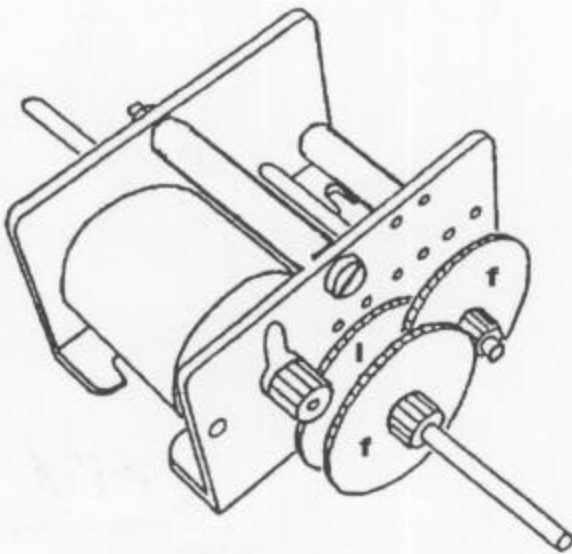

$r = 625 : 1$

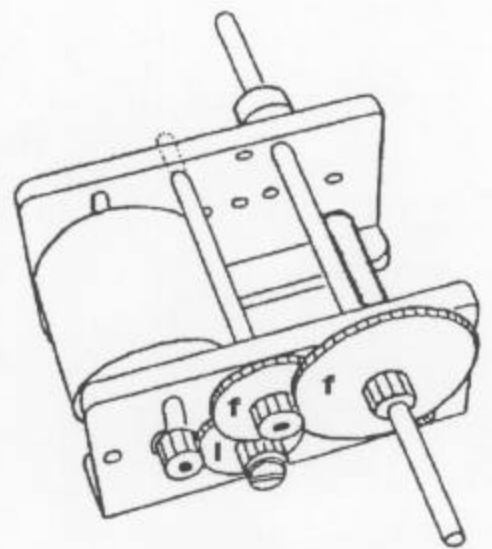

$r = 45 : 1$

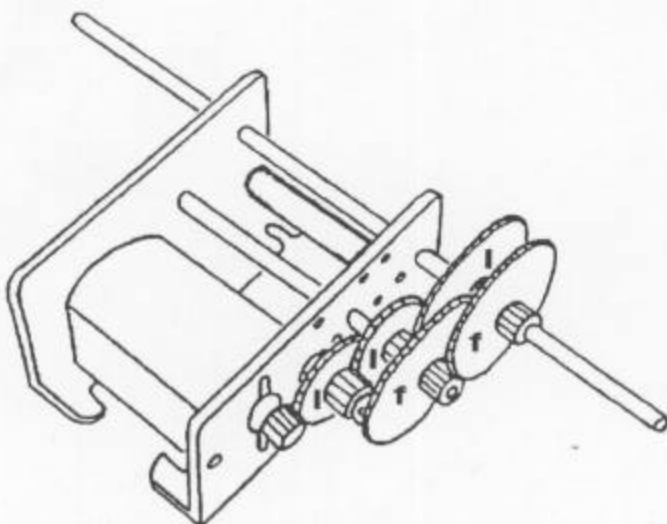

$r = 1125 : 1$

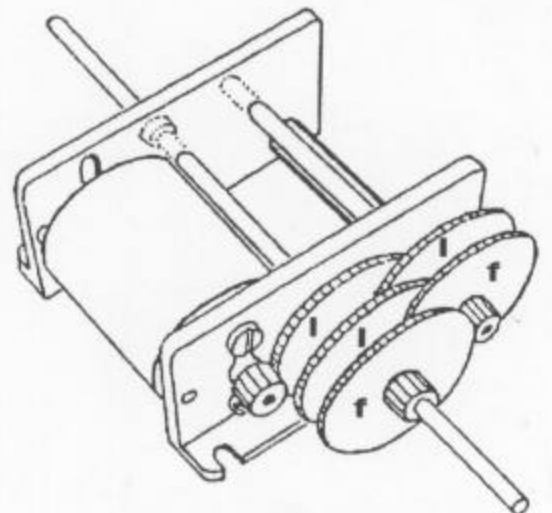

$r = 3125 : 1$

l = loose fit on 3 mm shaft

f = tight fit on 3 mm shaft

r = ratio